

## GUARANTEE

Your JPL Telecom product has been carefully manufactured and 100% tested using high quality assured components. It is guaranteed against faulty workmanship and materials for a period of 12 months from the date of purchase. In the unlikely event that a failure should occur, please contact the JPL Telecom dealer from which you purchased this product or visit [www.jpltele.com](http://www.jpltele.com) and follow our product returns procedure. You will be given a RMA number and instructions on how to return your headset.

Further help can be found on-line at [www.jpltele.com](http://www.jpltele.com) on our FAQs page.

**Note:** Removing the factory-applied warranty label on the in-line wire will void the warranty. Specifically exempt from warranty are limited-life consumable components subject to normal wear and tear, such as microphone windscreens, ear cushions and other accessories. Your statutory rights under common law are in no way affected by this guarantee. The warranty does not cover cosmetic damage or damage due to misuse, abuse, negligence, acts of nature, accident, disassembling or modification of, or to any part of, the product. The warranty does not cover damage due to improper operation, maintenance or installation, or attempted repair by anyone other than JPL Telecom. Any unauthorised repairs will void this warranty.

### LIMITED WARRANTY

Consequential and incidental damages, including without limitation, loss of property and those arising from breach of any express or implied warranty, are not the responsibility of JPL Telecom and to the extent permitted by law, are excluded.

In accordance with its policy of progressive product design, JPL Telecom reserves the right to change product specifications without prior notice.

\* Repair or replacement is at the discretion of the manufacturer.

### REGISTERED ADDRESS

#### UK Office: JPL Telecom Limited

Unit 1, Church Close Business Park, Church Close, Todber, Sturminster Newton,  
Dorset, DT10 1JH England

#### USA Office: JPL Telecom Holdings LLC

445 W Merritt Ave, Merritt Island, FL 32953, USA

Registered in England No. 5250754

*(NB. For product returns, please follow instructions and returns department address provided on our website. Returned products received at the registered addresses are likely to be returned to sender.)*



## QUICK START GUIDE

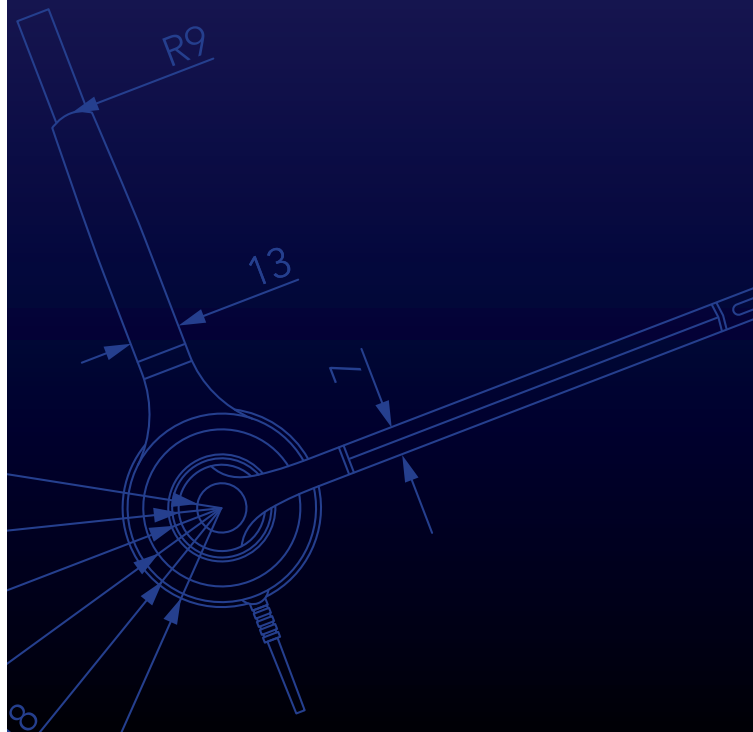

## Quick Start Guide

For full operating instructions please visit [www.jpotele.com](http://www.jpotele.com)

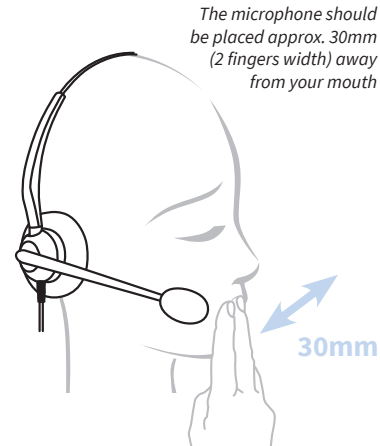
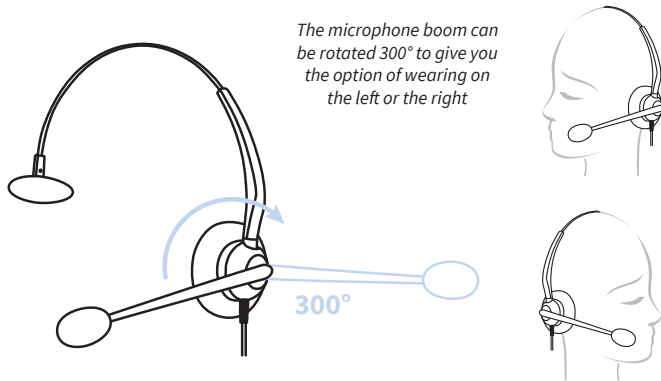

In the interests of hygiene it is advisable to replace the ear cushions of your headset every 6 months

